

A Good News Story Power & Recovery

Gerry Pageau, B.A.Sc., P.Eng, M.Eng
Process Engineer at HSPP since 1978

Presentation to ElderU



Bark & sawdust arrives with wood chips



The Port Mellon Mill does not process any logs. All wood is delivered as chips. Bark and other wood waste also arrives by barge and is used in the power boiler.



Chips arrive by barge as separate species »»

Hog fuel scows are the darkest because they mainly consist of bark. They are not suitable for making pulp but can be burned to produce steam in the power boiler.



Bye bye beehive burner >>

Lumber and plywood manufacturing generates waste material, chips, sawdust and bark. Old disposal was landfill & burning.

Wood Chemistry

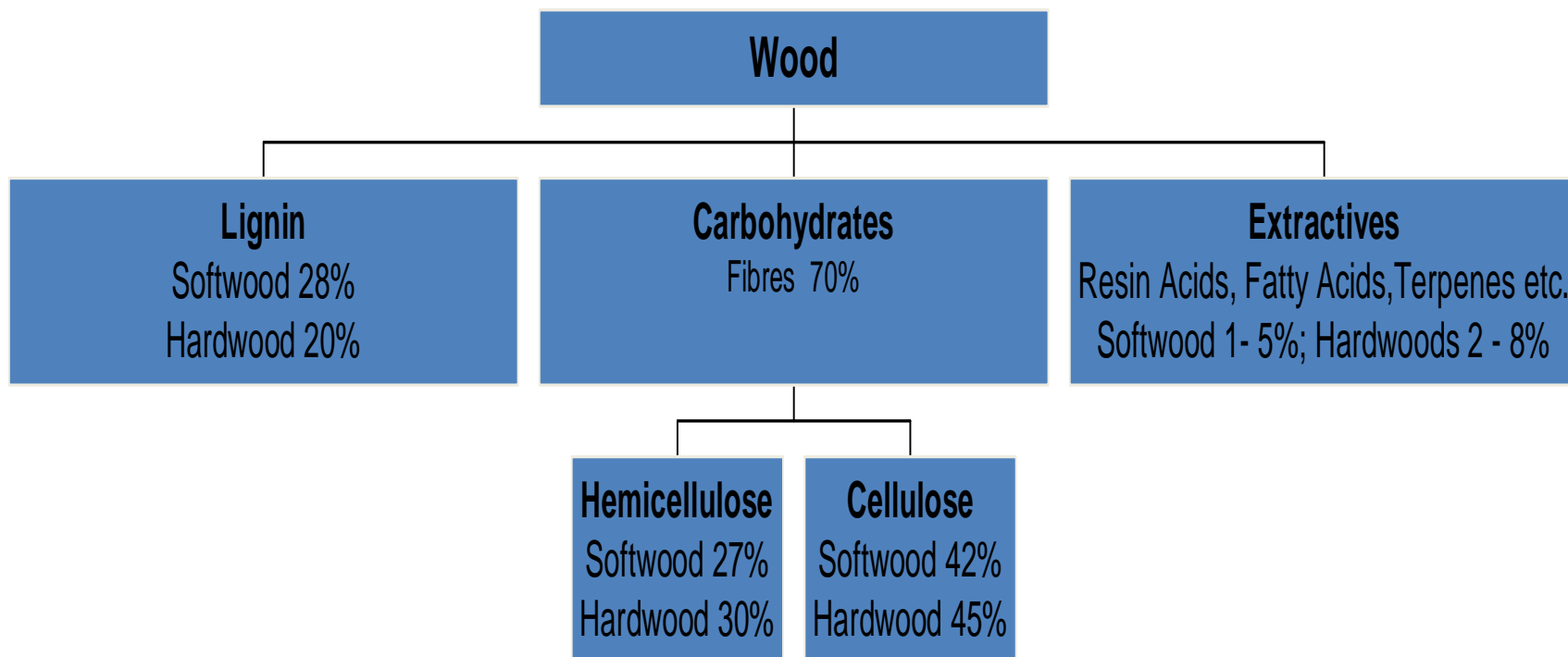

- ▶ In Kraft mill, chips are treated to obtain the cellulose product for paper. The remaining material goes to recovery.



A Digester is a big pressure cooker that removes lignin from wood chips. Most of the delignification work in the pulping process is done in the Digester.

The ultimate goal of Kraft pulping is to remove as much lignin as possible without damaging fibers.

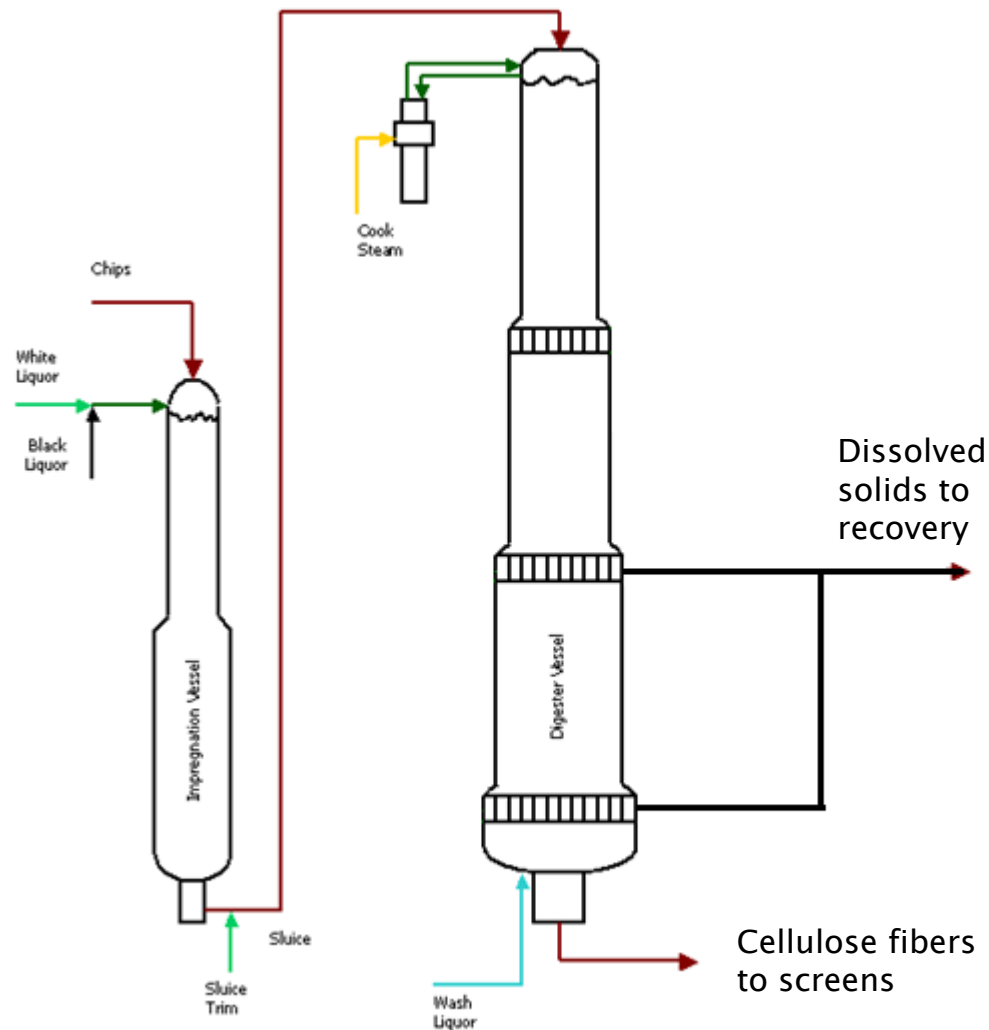

Impregnation Vessel and Digester

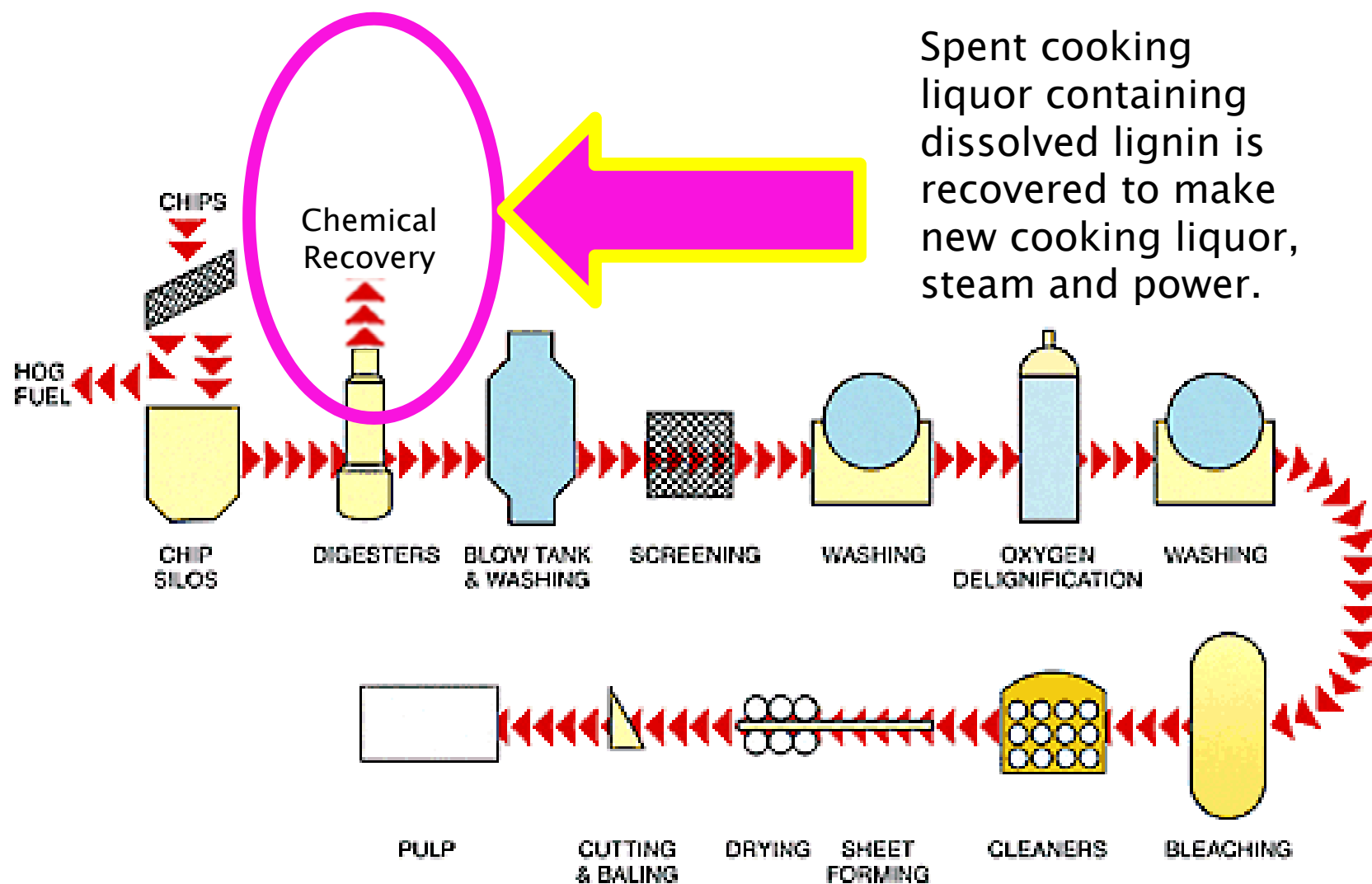

The digester is where lignin, hemicellulose and other materials are dissolved. This frees the cellulose fibers which proceed to screening, washing and other steps toward bales.

Chemical Recovery

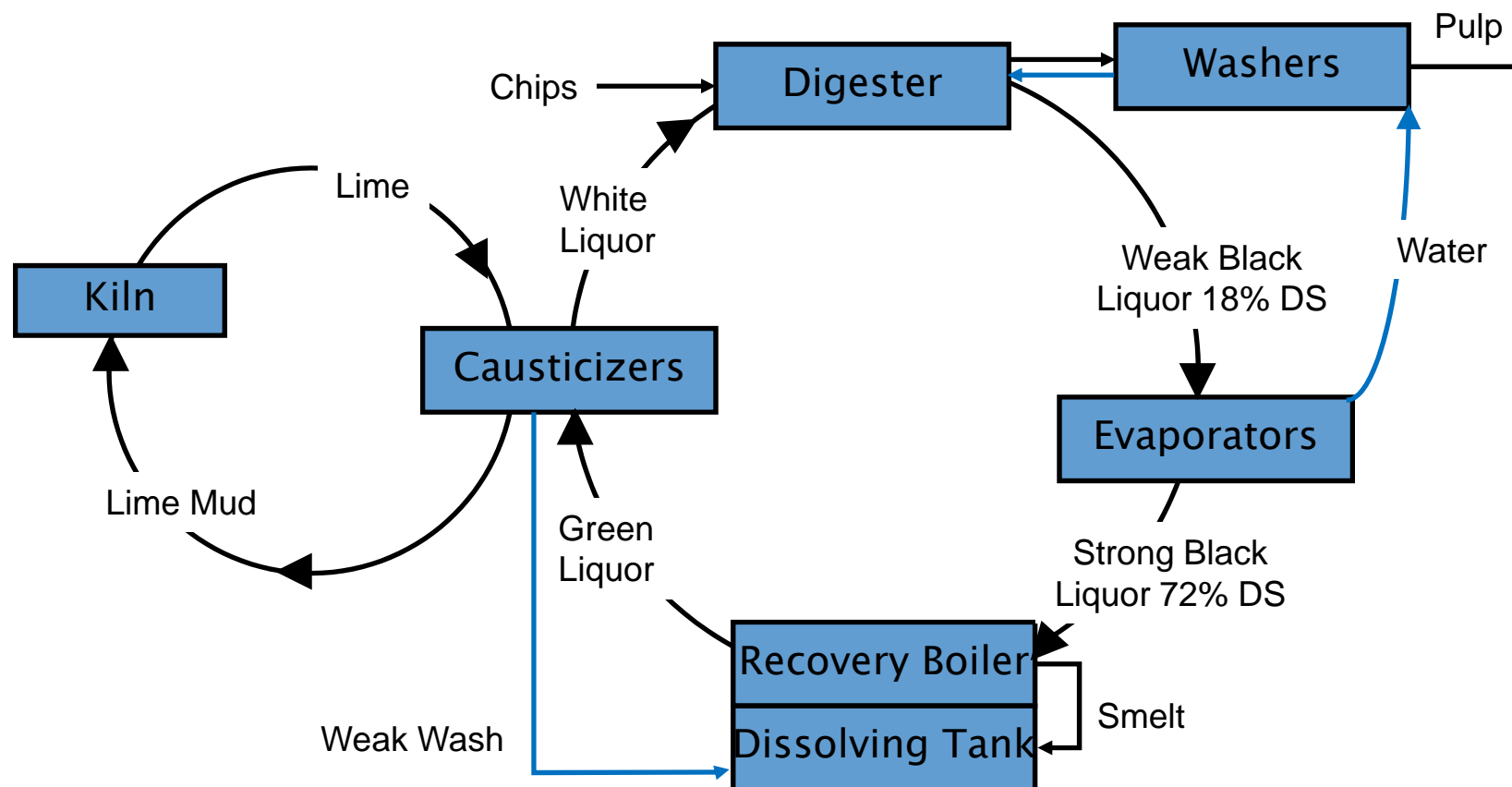

Dissolved solids from digester are concentrated by evaporators, water returns to washers. Strong black liquor is burned in recovery boiler, smelt, the spent cooking liquor is dissolved in weak wash and sent to causticizer.



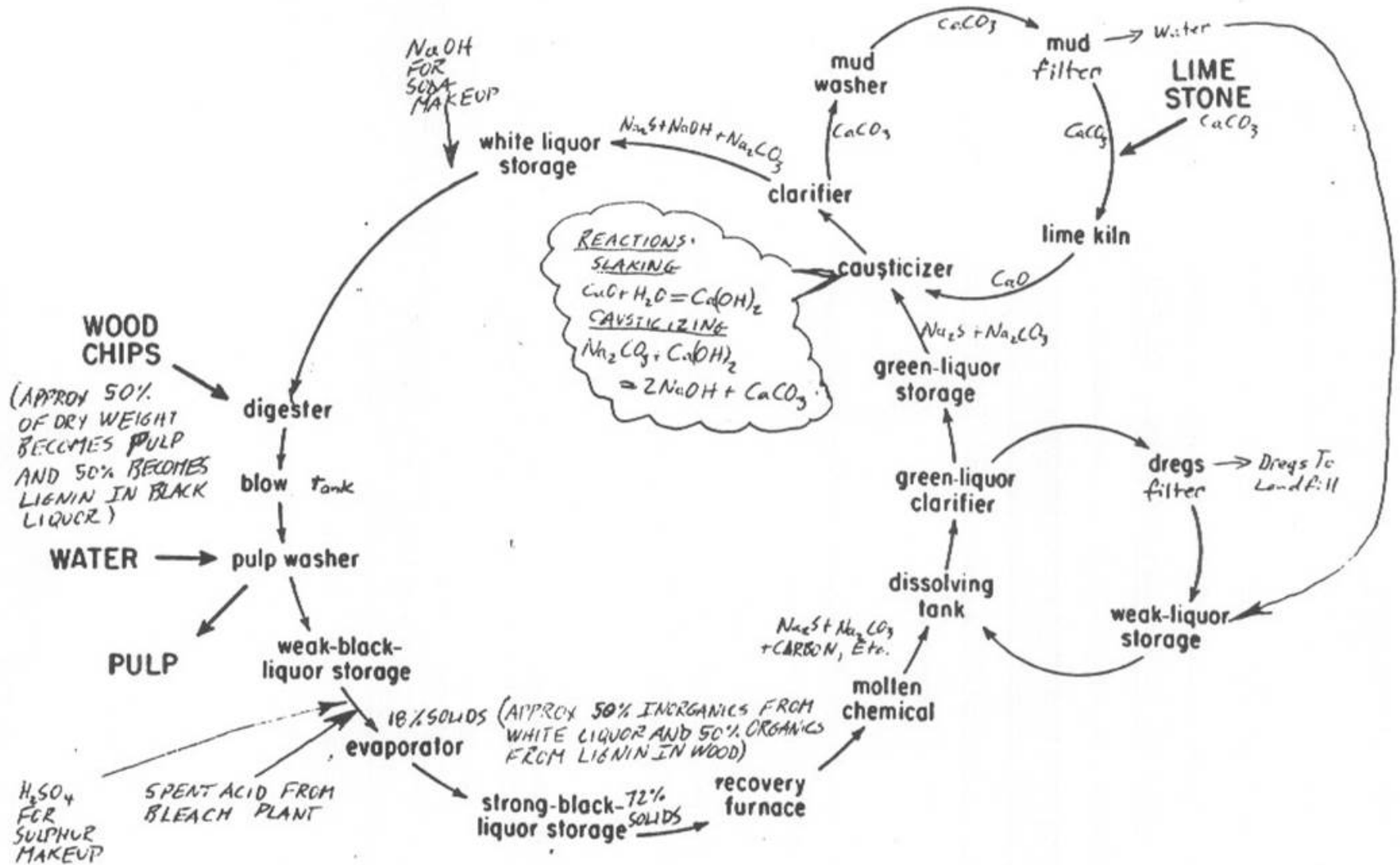

Fig. 8-8 Diagram showing cyclic nature of the kraft recovery process.¹⁸



By far the largest building on the Sunshine Coast, the recovery boiler is about 12 stories tall.

It can process about 3,000 tonnes of dry solids per day and produce up to 400 tonnes of high pressure steam per hour.

One of the key functions of the recovery boiler is to recover cooking chemicals so they can be recycled back to the digester.



Recovery Boiler



Top of stack



Dissolving tank scrubber and recovery boiler precipitator remove particulates before flue gas leaves via the stack. Because the scrubber uses water, there is often a small plume of steam visible.

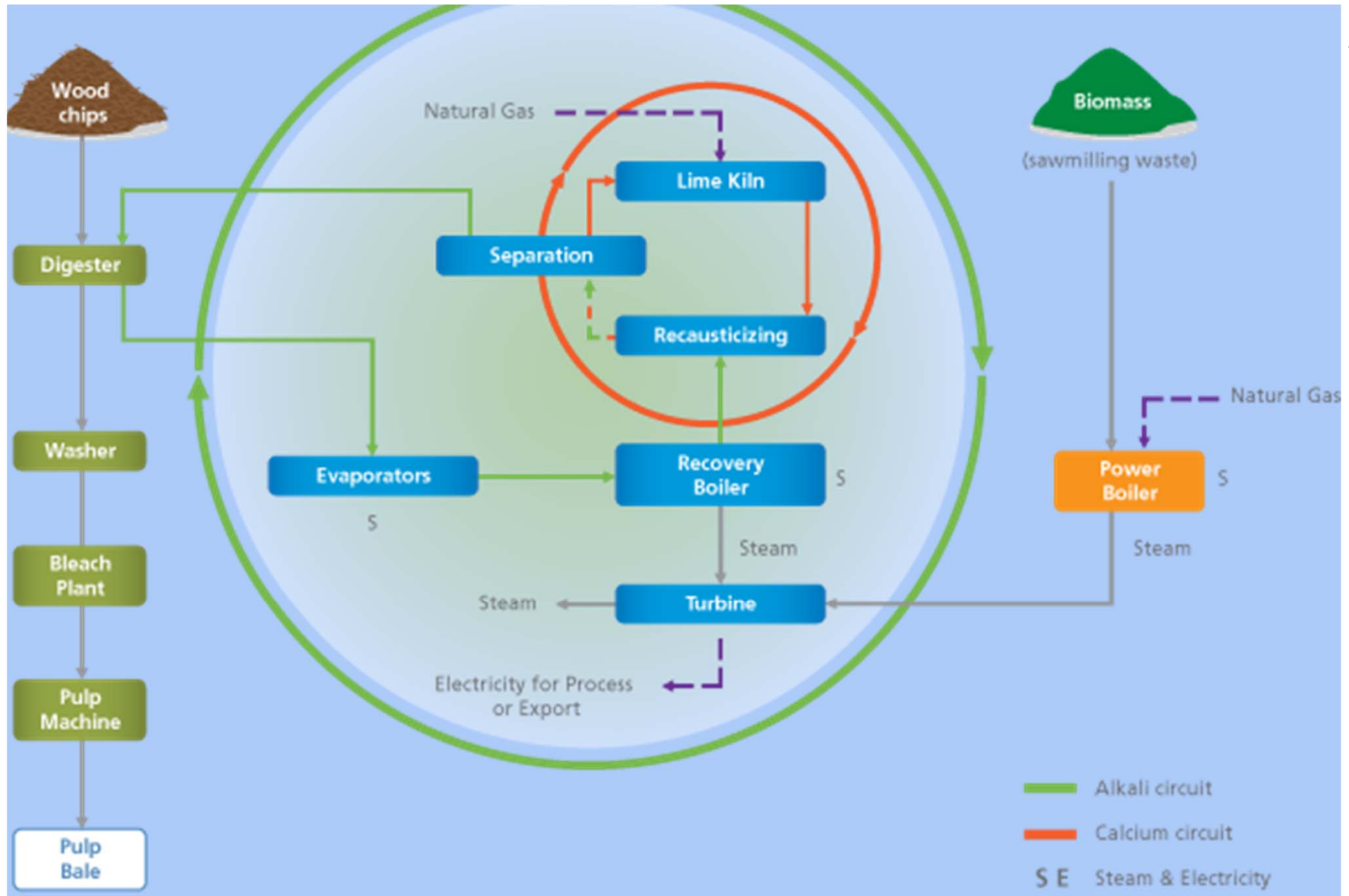

Kraft Pulp Mill Main Process Units



Hog crane unloads bark fuel from barge »»



Hog bucket empties the barge »»



Hog fuel conveyed from crane to pile »»

The power boiler burns hog fuel in a fluidized sand bed to produce up to 240 tonnes of HP (high pressure) steam per hour.

This steam is combined with HP steam from the recovery boiler and passes through our two turbo generators to produce MP steam, LP steam and electricity.

This power is green since fossil fuel is only needed for start-up or during rare upsets.

The TGs typically generate 90 MW of electricity and are tied into the BC Hydro grid. This is enough green power to supply 36,000 homes. 



Power Boiler

Power boiler stack

An electrostatic precipitator removes particulates and fly ash from the boiler flue gas.

Often the plume is invisible because there is very little water vapour.

In distance is plume of water vapour from the paper drier and TMP blow vent. This is most visible evidence of the mill yet is almost completely innocuous.

Stack emissions are regulated. Continuous measurements are checked regularly by independent testers and reported to government agencies. 





Lake 7 – Rainy River Storage



There is a small lake and dam with remote controlled outlet valve which is used to supplement the Rainy river water flow during the late summer and early fall.



Base of the Lake 7 dam



Solar powered instrumentation monitors the lake conditions and the operator from recovery control room can change how much water is released into the Rainy river by adjusting the valve at outlet of the dam by remote control.



The water treatment plant



River water passes through this large pool. Leaves and twigs are skimmed off the top while sand and silt settle to the bottom. This provides clean water to the mill for pulp washing, boiler feed water, chemical production and hundreds of other uses.



Effluent is treated in multiple steps:

- 1) primary clarifier removes suspended solids (mainly fiber)
- 2) cooling towers adjust temperature while acid or caustic are added to control to neutral pH.
- 3) UNOX system treats effluent with pure oxygen gas to remove BOD and COD using microorganisms.
- 4) two secondary clarifiers remove the bugs
- 5) treated effluent is released through a diffuser into Howe Sound.





HSPP pulp is our customer's raw material >>>

A primary use is as reinforcement for paper products which contain large amounts of recycled or mechanical pulp.



Loading paper rolls with vacuum crane

© 2015 Howe Sound Pulp & Paper Corporation
a Paper Excellence Company



HSPP has been making use of sawmill waste  for over 100 years and has now added green power to our pulp & paper product line.